

Contents of Manual:

1-1. Unpacking -----	2
1-2. Transportation instruction -----	2
1-3. Major parts-----	3
1-4 Unpacking and Checking List-----	4
1-5 Site Considerations-----	5
1-6 Items Needed for Set Up -----	6-9
1-7. To assemble the drill chuck and mount it to the spindle-----	10
1-8. Setting the machine instruction-----	11
2. Safety instruction-----	12-14
3-1. Control panel instruction -----	15
3-2. Operation illustration and procedure-----	16
3-3. Operation tips and sound pressure -----	17-18
3-4. Withdraw drill bit -----	19
4. Trouble - Shooting -----	20
5. Maintenance -----	21
5-1. Feed Shaft Spring Tension-----	22
6. Specification -----	23
7. Control circuit diagram and component part list -----	24-25
8. Drawing and parts list -----	26-28

1-1. Unpacking:

Before unpacking, make sure the carton configuration not damaged, broken or parts extruded, if any above defect case is found, contact your retailer to change a new one as soon as possible.

Unpacking procedure:

1. Carefully open the carton. (Pull it from the bottom to the top)
2. Take out and read the manual, check parts list and relative attachments.
3. Inspect the machine outline if it is in normal condition or not. Crack, rust, collapse and separate are strictly prohibited.
4. Cleaning the surface of the machine.
5. Assemble the drill machine based on manual, instruction guide.

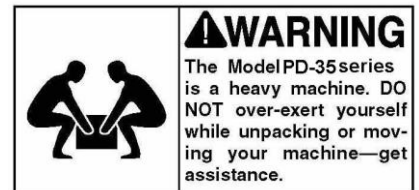

1-2. Transportation instruction:

1. Please refer to instruction manual in specification and machine weight to arrange handling manner. Be sure to use capable fork – lifter or hoist to lift of machine.
2. The handling and transportation shall be carried out by qualified persons.
3. Fork – lift or hoist can be used in handling and shall be operated by qualified driver.
4. While transportation, keep attention to the balance of machine.
5. During handling, the machine shall be lifted only in vertical direction.
6. Before handling, make sure all movable parts are secured in their position and all movable accessories should be removed from machine.
7. The steel rope should average pull the machine head, table and column tightly.
8. Keep all the processes in a carefully and slightly condition.
9. Bump or crash are strictly prohibited. It will cause precision shift and electronic controller damaged.

1-3. Major Parts:

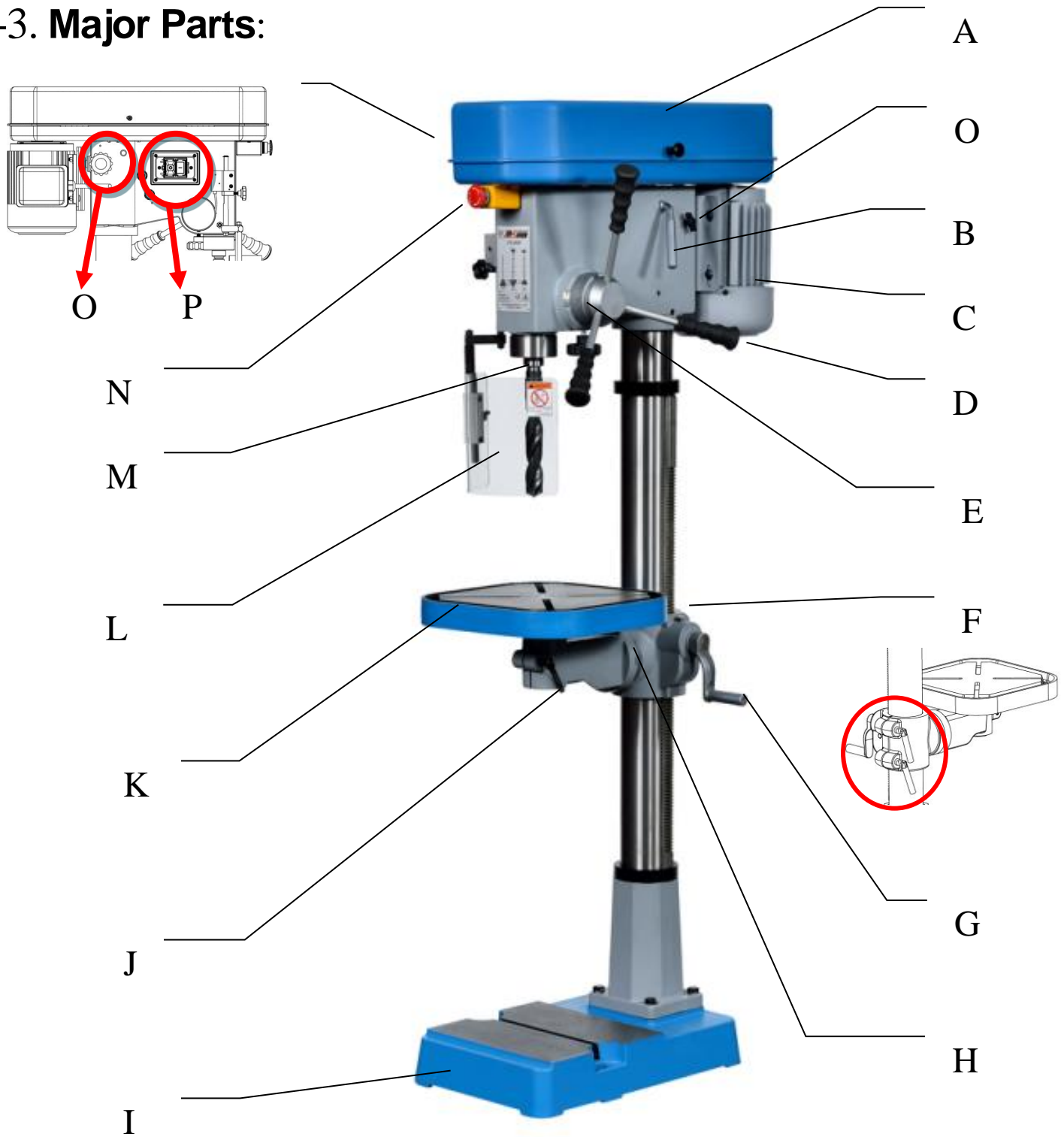

A= Pulley Cover	I= Base
B= Motor Handle	J= Locks table rotation
C= Motor	K= Table
D= Feed Handle	L= Chuck Guard
E= Depth Stop	M= Spindle
F= Locks table height	N= Emergency Stop Button
G= Raises/lowers table	O= Belt Tension Lock
H= Displays current table-tilt angle.	P= ON/OFF Switch

















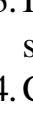

1-4 Unpacking and Checking List

1. Unpacking

Before unpacking, mark sure the carton configuration have no damaged, broken or parts extruded, if found above defect case, contact to your retailer for change a new one as soon as possible.

Unpacking procedure:

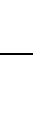
1. Carefully open the carton. (Pull it from the bottom to the top)
2. Take out and read the manual, check parts list and relative ancillary.
3. Inspect the machine outline if it is in normal condition or not. Crack, rust, collapse and separated are strictly prohibited.
4. Cleaning the surface of the machine.
5. Assembly the drill machine base on manual, instruction guide.

		Qty	
	1	Base	1
	2	Table Support Assembly	1
	3	Table	1
	4	Chuck	1
	5	Chuck Guard	1
	6	Arbor MT2xJT3 For PD28	1
		Arbor MT3xJT3 For PD35	
	7	Headstock Assembly	1
	8	Column Ring	1
	9	Pulley Cover Knob	1
	10	Grip	3
	11	Feed Handle	3
	12	Column	1
	13	Hex Wrench 3mm	1
	14	Hex Wrench 4mm For PD35	1
	15	Hex Wrench 5mm For PD28	1
		Hex Wrench 6mm For PD35	1
	16	Drift Key	1
	17	Rack	1
	18	Raises/Lowers table	1
	19	Hex Bolt	4
	20		

1-5 Site Considerations

Working Clearances

Consider existing and anticipated needs, size of material to be processed through each machine, and space for auxiliary stands, work tables or other machinery when establishing a location for your machine. See **Figure 01**.

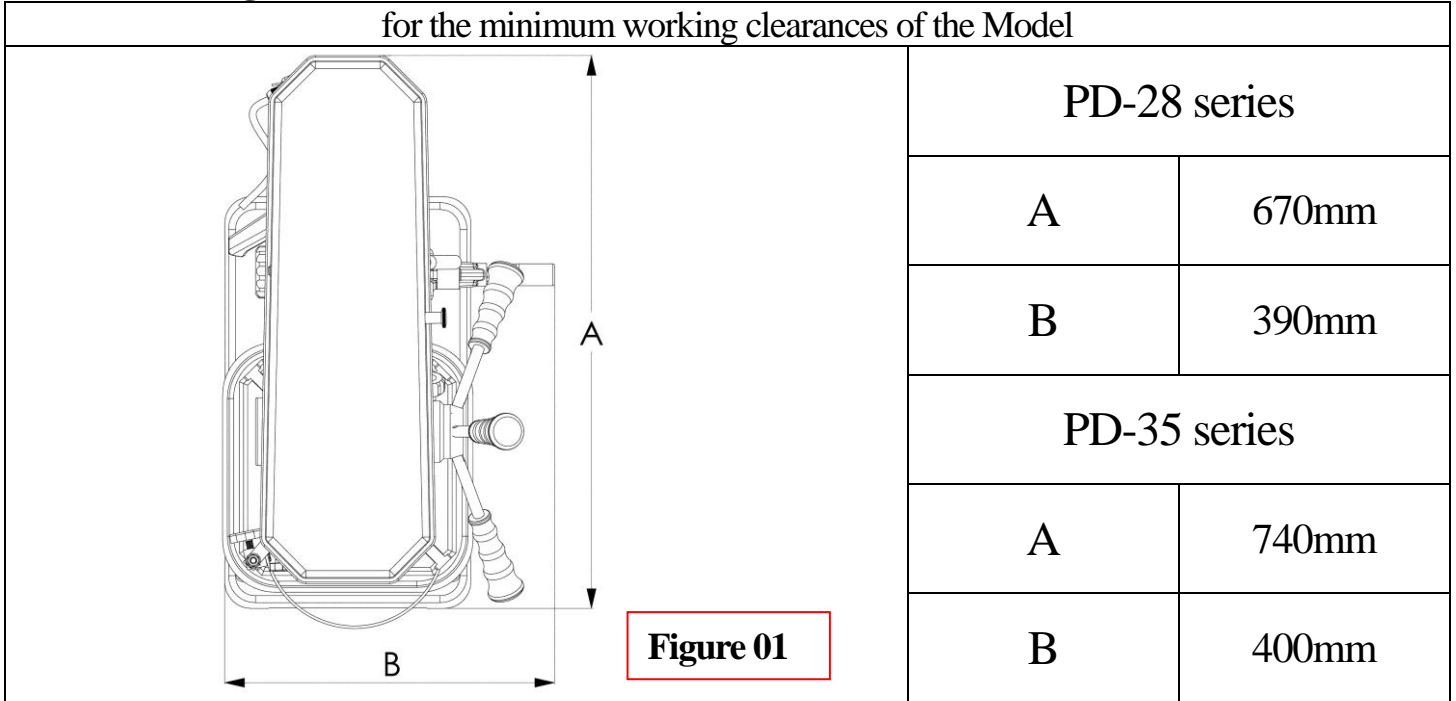

1-6 Items Needed for Set Up

1.Column and Base

The column must be secured on the base to properly assemble your drill press.

To secure the column to the base:

1. Place the column on the base and align the mounting holes.
2. Secure the column to the base with the four hex bolts, as shown in **Figure 02**

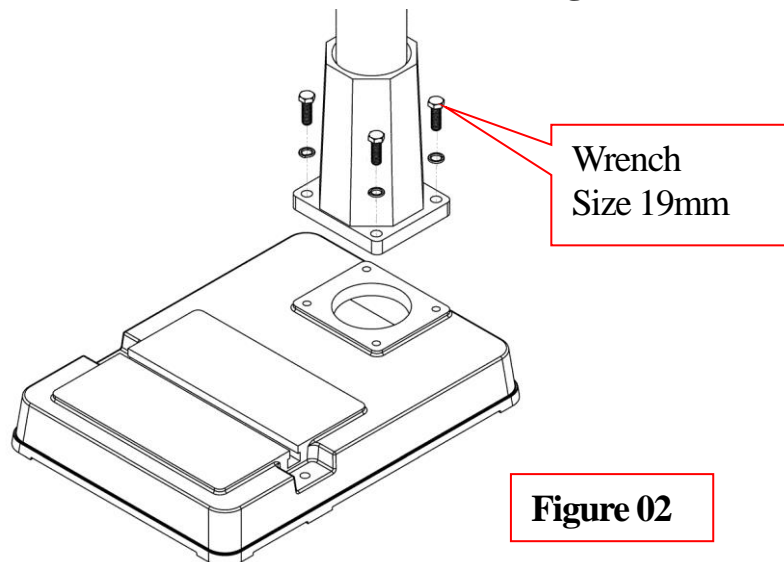

2. Table Support

The table support must be installed as described to properly assemble your drill press.

To install the table support:

1. Check to make sure the pinion is inserted into the table support, as shown in **Figure 03**, so the pinion and gear teeth mesh together.

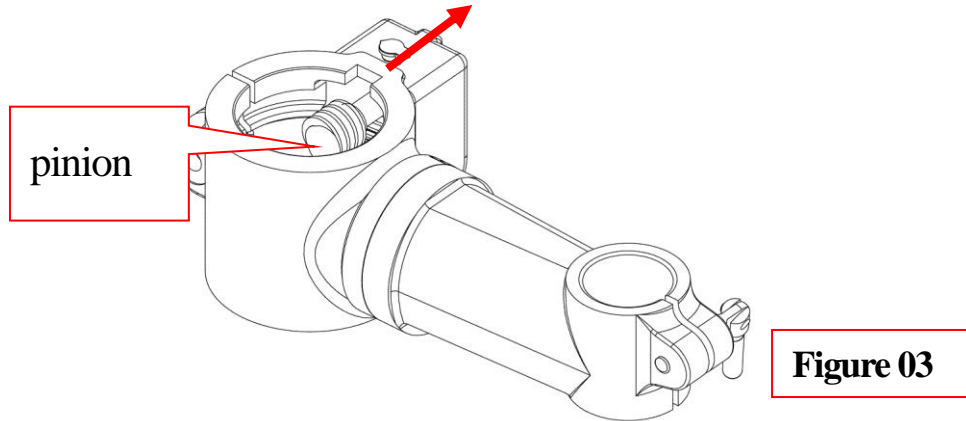

2. Mark the top of the rack, as shown in **Figure 04**, to keep track of which end is up.
3. Place the rack inside of the table support assembly, mesh it together with the pinion, and slide the table support/rack assembly over the column, as shown in **Figure 04**.
4. Slide the column ring over the column with the beveled edge facing down (**Figure 05**), fit the beveled edge of the column ring over the rack, and tighten the setscrew. Note: Do not over-tighten the setscrew or you may split the column ring. Also make sure the rack is seated firmly in the lower ring. (**Figure 06**)

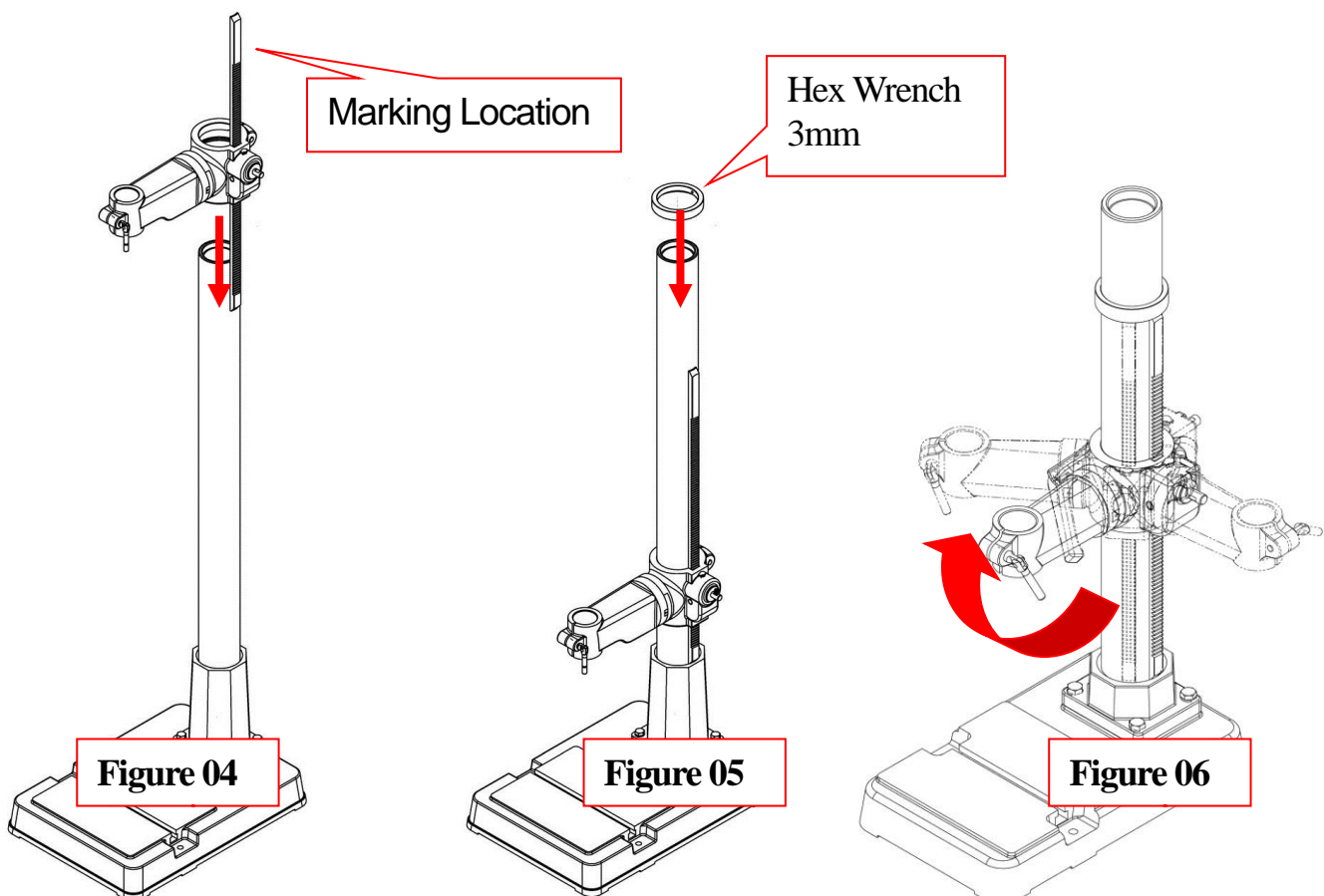

5. Install the crank lever over the pinion shaft, and tighten the setscrew in the crank handle against the flat part of the pinion shaft. **(Figure 07)**

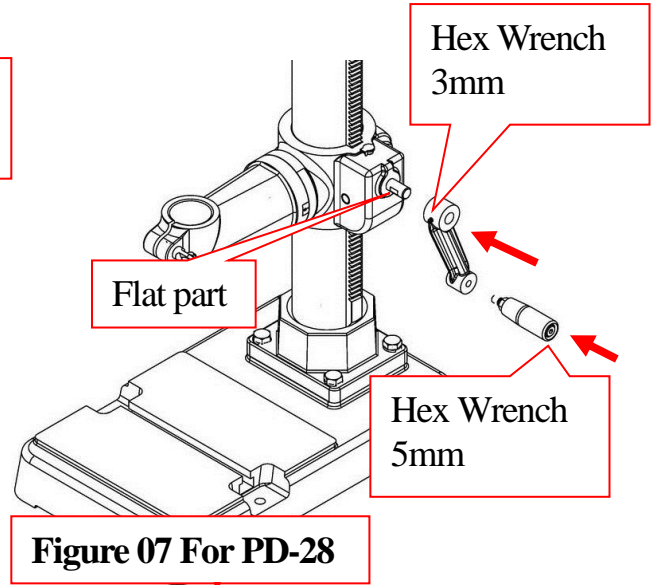
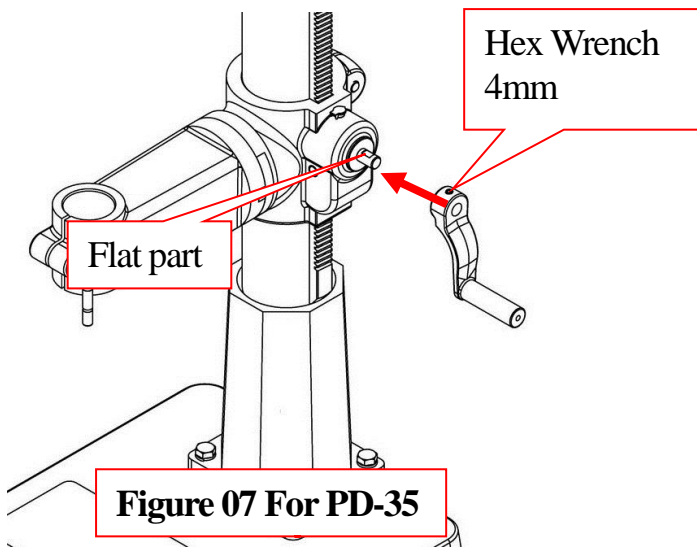

6. Insert the table shaft into the table support assembly. Tighten the small locking lever **(Figure 08)** to secure the table in the table support assembly

7. The headstock must be mounted on the column/base assembly before the drill press can be operated. Moving and installing the headstock is a two-person job. **(Figure 09)**

7-1. Loosen the two set screws on the right side of the headstock enough so they are flush with the inside pocket of the headstock.

7-2. With the help of an assistant, lift the headstock assembly above the column, and gently slide it down the column as far as it will go.

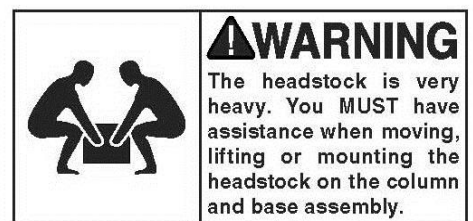
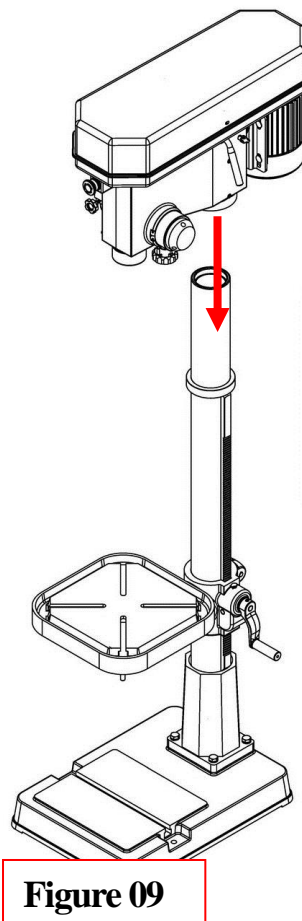
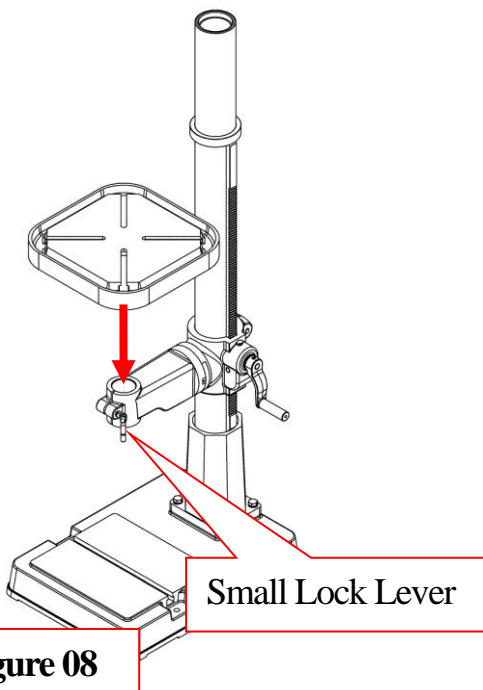

9. Suspend a plum bob from the center of the headstock spindle so it is over the tape/ruler as shown in **Figure 11**. Center the headstock directly over the base as indicated by the plum bob and ruler.
10. Tighten the two headstock setscrews to the column, as shown in **Figure 11**.

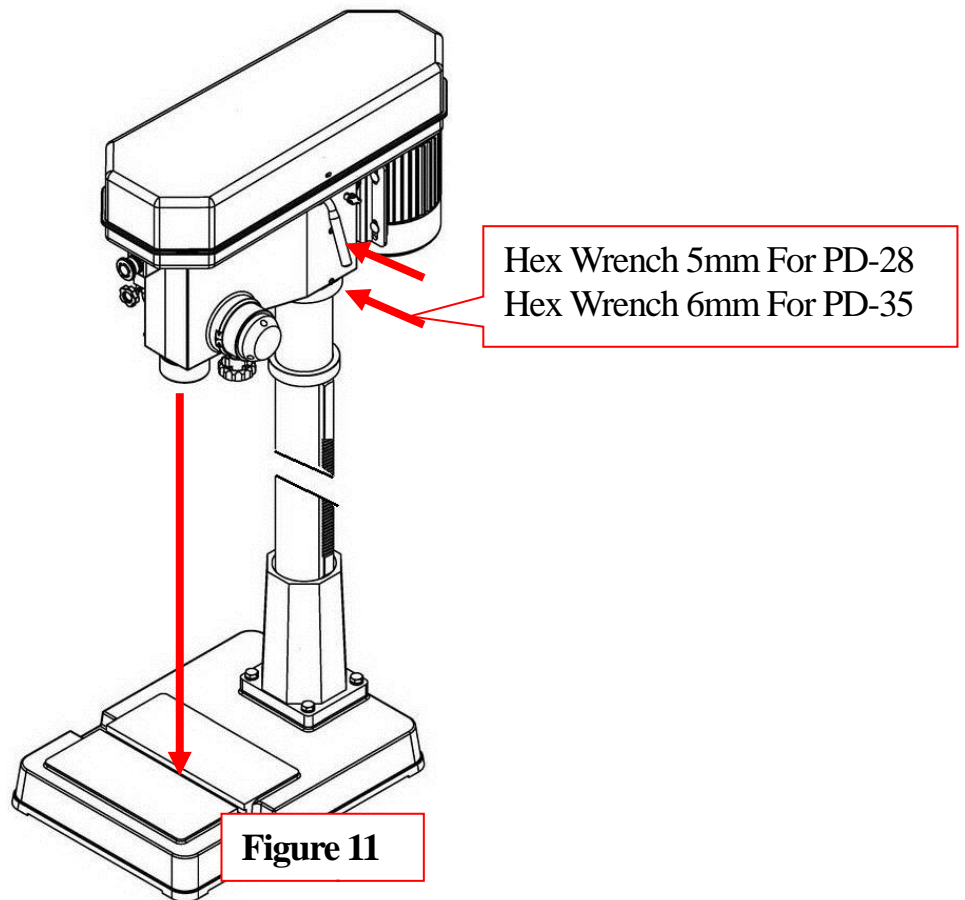

11. The downfeed handles must be installed to operate the drill press.

To install the downfeed handles:

Thread the handles into the spindle hub, as shown in **Figure 12**, and tighten.

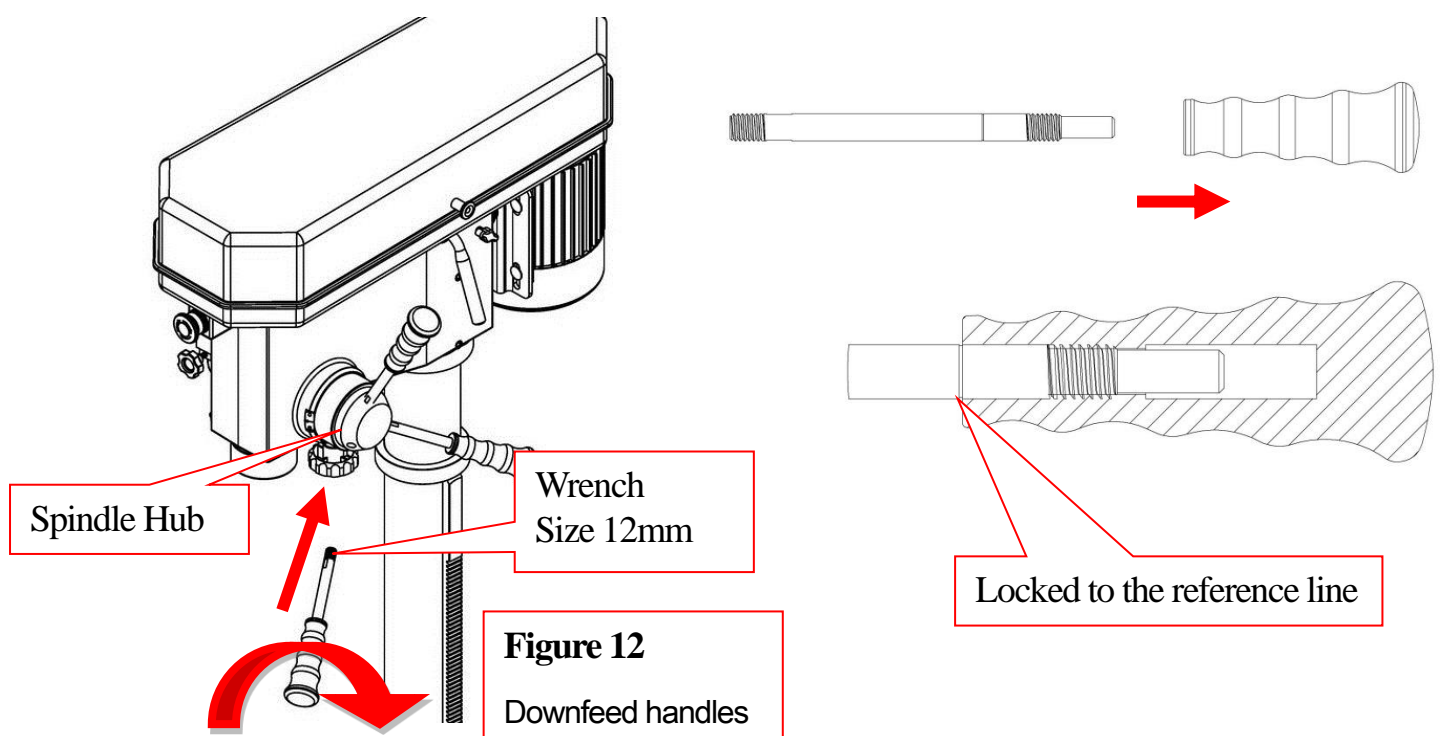

12. Install the belt cover knob in its place (see **Figure 13** for location).

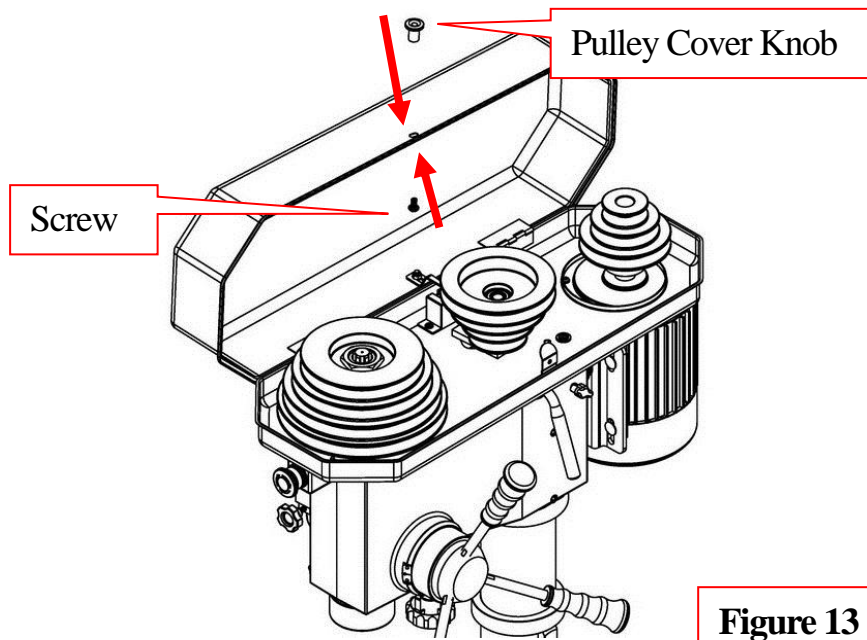
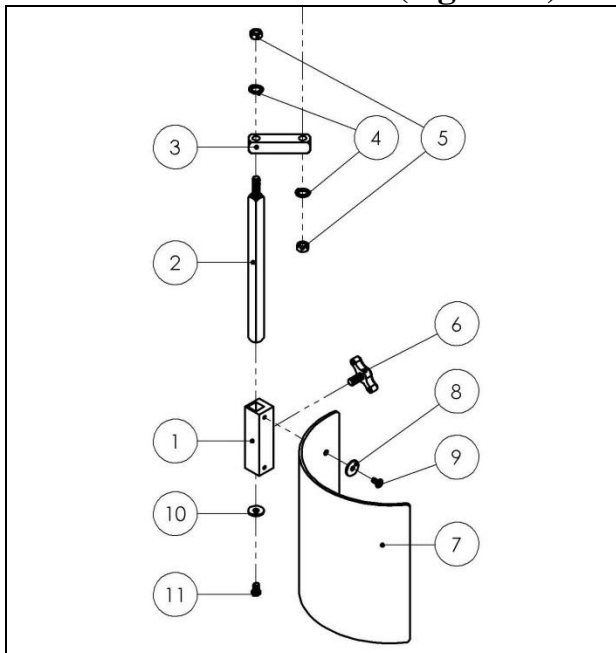

Figure 13

13. Chuck Guard & Parts List (**Figure 14**)



		Qty
1	Safety Guard Slide	1
2	Lower Bracket Rod	1
3	Support Arm	1
4	Spring Washer	2
5	Hex Nut	2
6	Lead Bolt	1
7	Safety Guard	1
8	Washer	2
9	Screw	2
10	Washer	1
11	Screw	1

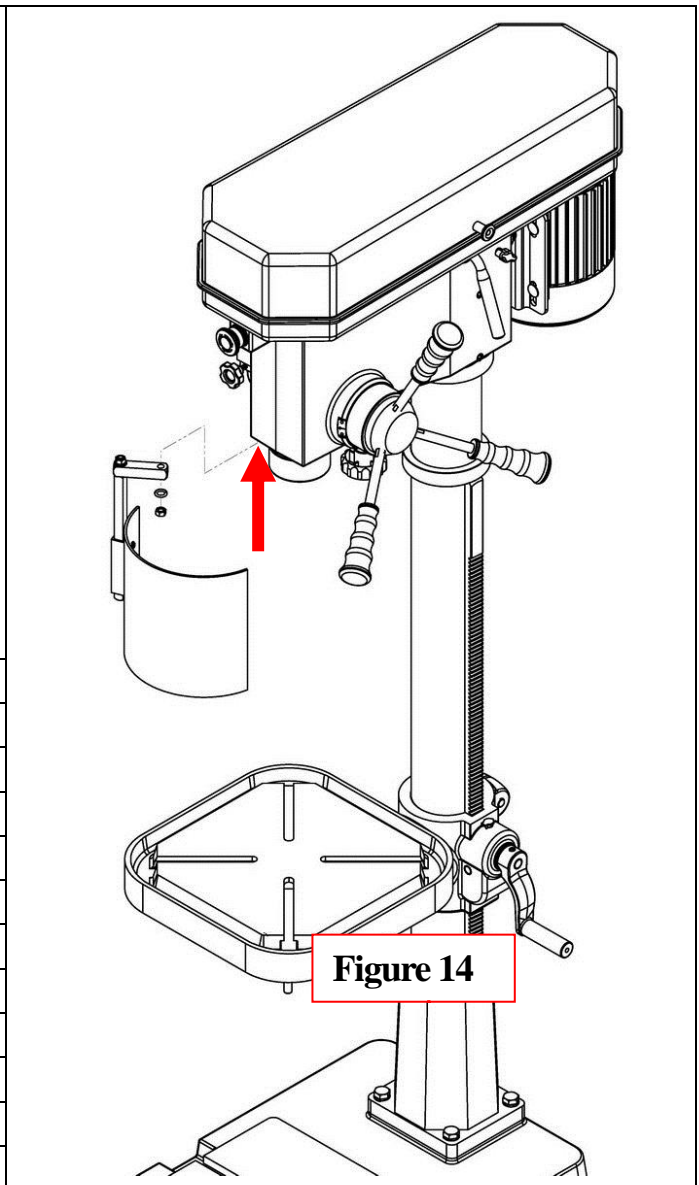
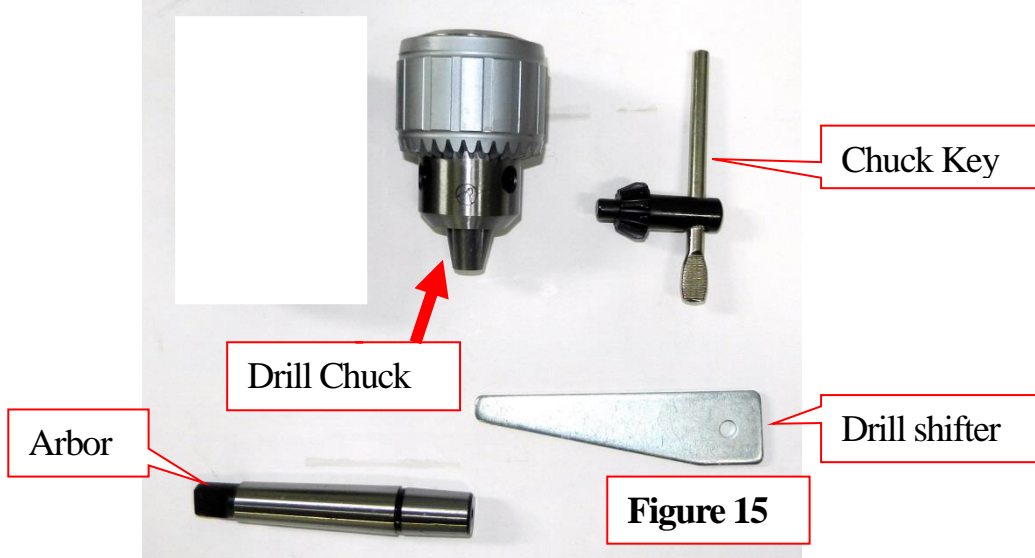

Figure 14

1-7. To assemble the drill chuck and mount it to the spindle:

1. The drill chuck attaches to the spindle by means of the arbor, shown in **Figure 15**. Matched tapers on the arbor and the inside of the chuck create a semipermanent assembly when properly joined.



2. Use mineral spirits to thoroughly clean the drill chuck, arbor, and spindle sockets and dry all surfaces before assembly. Follow all safety warnings on the container of the mineral spirits. Failure to clean the mating surfaces may cause the tapered fit to loosen during operation, resulting in separation and an unsafe condition. **Figure 16.17.18**



2. Use the chuck key to adjust the jaws of the drill chuck until they are inside the drill chuck body. **Figure 19.20**

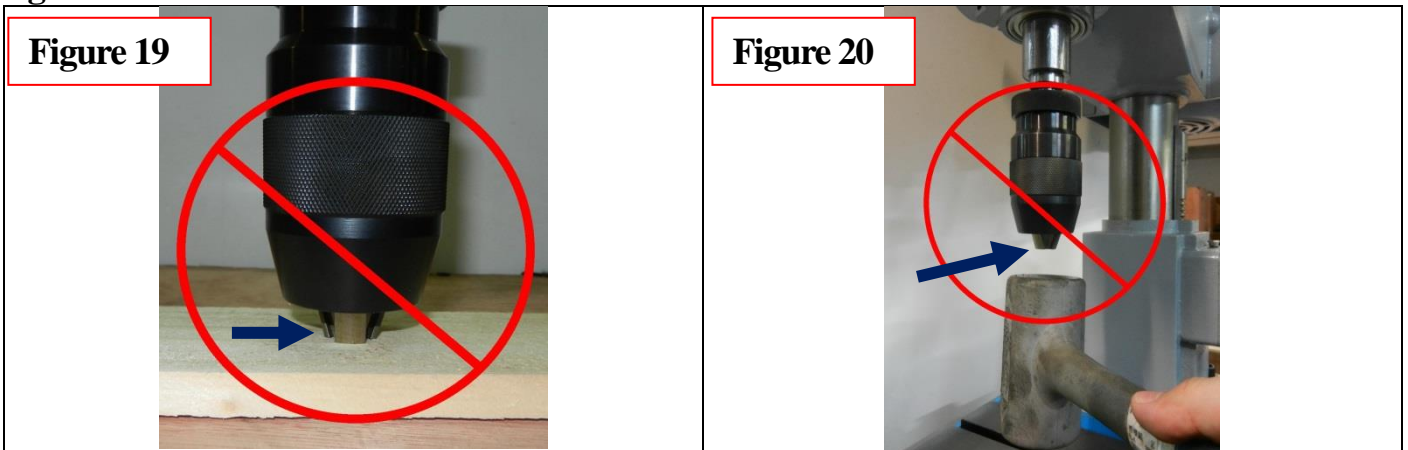

3. Place the drill chuck face down on a workbench. The arbor has a short taper and a long taper. Place the short taper into the socket in the back of the drill chuck and tap it with a rubber or wooden mallet, as shown in **Figure 21**. If the chuck fails to remain secure on the arbor, repeat Steps 16 & 17.

4. Slide the arbor into the spindle socket while slowly rotating the drill chuck. The socket has a rectangular pocket where the tang (or flat portion of the arbor shown in **Figure 21**) fits into.

5. Seat the chuck with a rubber mallet, as shown in **Figure 22**.

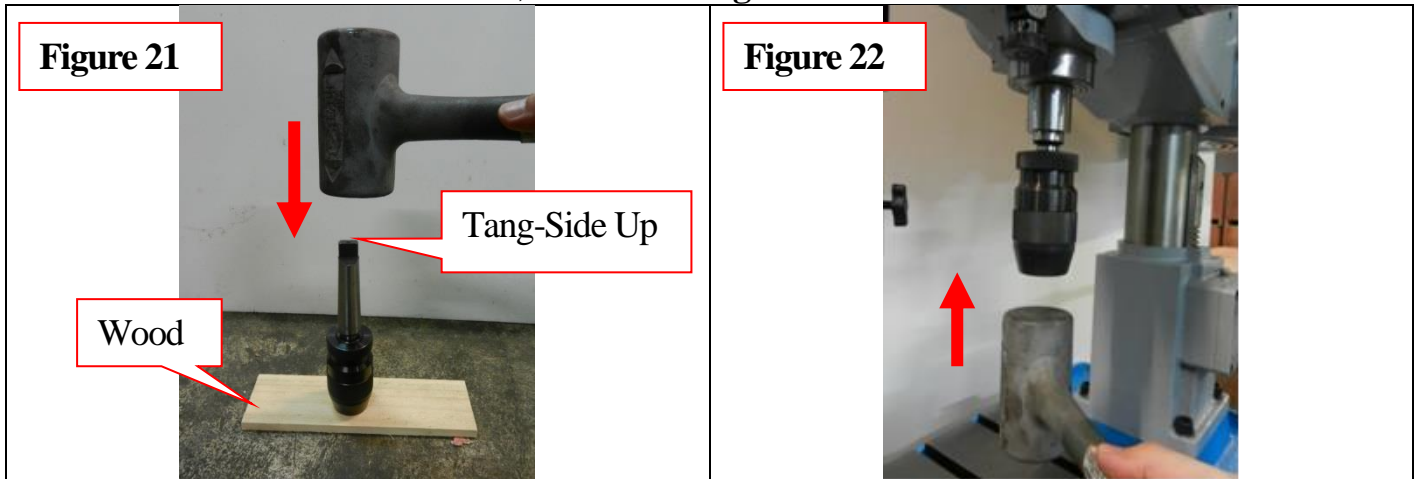

1-8. Setting the machine instruction:





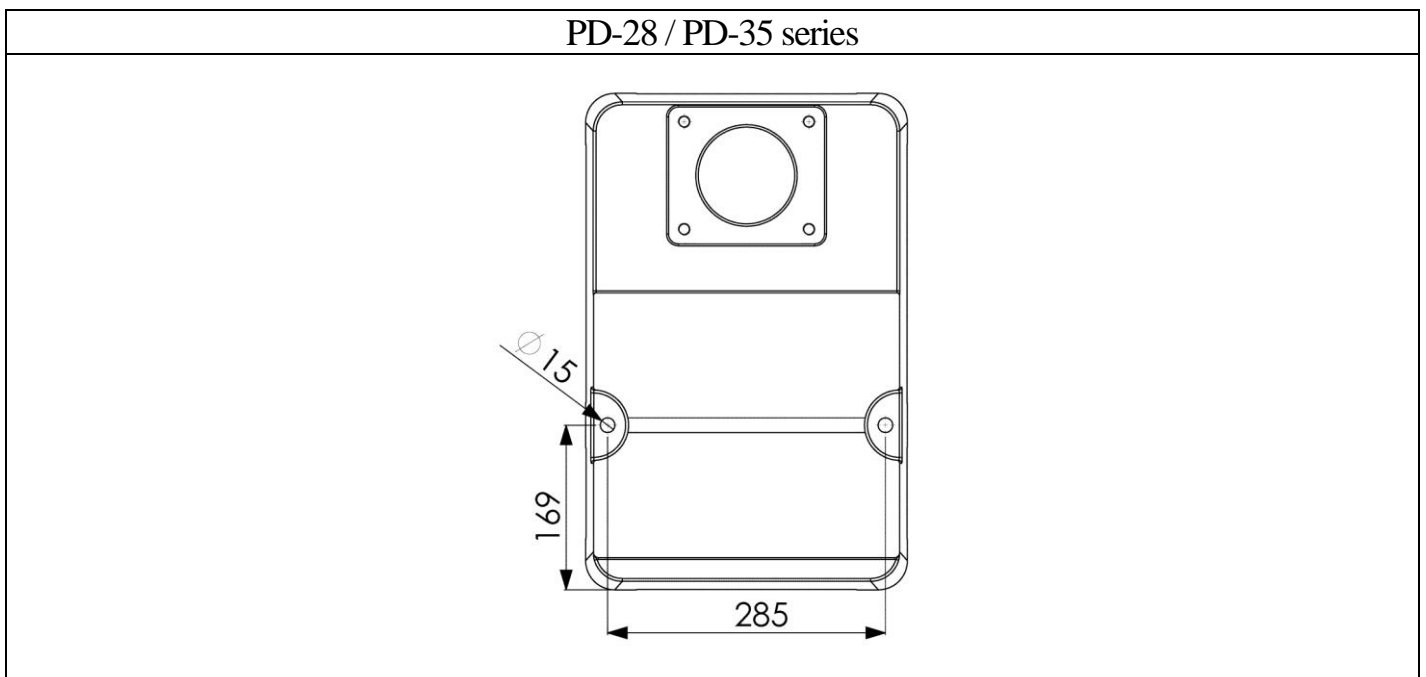

1. The machine base with setting hole will be set on concrete floor.

The outlined procedures of setting the machine	MODEL	AREA	SETTED SCREW
	PD-28 series	X=900×700	M12
	PD-35 series	X=900×700	M12

2. The dimension of setting hole:

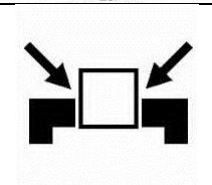

2. Safety Instruction:

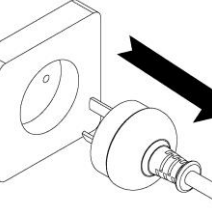
	<p>Please read the safety instruction and operation instruction carefully.</p>
	<p>Please do wear a safety glass to avoid any material from coming into the eyes whilst operation.</p>
	<p>Please do wear ear mufflers or earplugs to avoid any noise from hurting the listening whilst operation.</p>
	<p>Please do wear proper work clothing whilst operation. Loose clothing or tie are prohibited to avoid any unnecessary incident.</p>
	<p>If a operator has long hair, please do fix the hair or use cap to avoid the hair from being drawn into it.</p>
	<p>A processing workpiece shall be fixed firmly to avoid it from being thrown out whilst operation.</p>
	<p>Please keep both hands far from the rotating tool whilst operation. Cotton gloves are prohibited to avoid from being drawn into cutter.</p>
	<p>Please pull out the power plug to avoid any electric shock incident whilst product maintenance or repair.</p>

1. Make sure the power voltage is for the machine. Before connecting the plug to socket, it is necessary to check the power spec. to avoid any damage occurring.



2. If the machine is not used for a long time, the plug should be disconnected.

3. Never put the power cable near the fire or water environment, to break or press the power cable is not allowed.

4. It shall be stable and securely fixed in machine installation procedure for the machine to be used safely.

5. The working piece must be tightly fixed on table by vise or clamp.

6. Use recommended cutting liquid; consult the owner's manual for recommendation.

7. Feed speed should be executed under safety scope, please refer to manual 3-3.

8. Wear proper apparel, no loose clothing, gloves, neckties, ring, and bracelet during operation. Always wear safety glasses, cap and specific clothes.

9. Check all parts are in place and securely locked before transportation. Bump and crash are prohibited.

10. Regular maintenance and repaired should be executed in accordance with the rules of manual.

11. Use the industrial suction to clean the chip is recommended.

12. Use carrier to move the working piece which the weight is more than 10 kg is recommended.

13. Wear safety gloves when install the drilling bit or tooling to avoid hurting your hand is recommended.

14. This machine only be used following material brass, cast iron, steel, iron, aluminum .

15. It is prohibited to open the pulley cover during operation.

16. It is prohibited to use damaged or cracked parts

17. It is prohibited to remove the guard cover away during operation.

18. It is prohibited to move the table when machine is during operation.

19. It is prohibited to operate this machine beyond the limit of its capacity.
20. Refer to this instruction for details.
21. It is prohibited to insert one's hand or finger into the hole of working piece during operation.
22. It is prohibited all visitors and children should stand near work area while the machine during operation.
23. It is prohibited to wear gloves, neckties, ring, bracelet and loose clothing during operation.
24. It is prohibited to use plastic and wooden working.
25. Check again before switch on power,
 - A- Make sure the power voltage is for the machine.
 - B- Make sure the machine is completely assembled and installed
 - C- Make sure chuck, working table, working piece are completely secured or tightly fixed.
 - D- Make sure the chuck key is removed from chuck.
 - E- Make sure drill bit or tooling need to be fixed in the chuck.
26. Switch off power at once;
 - A- When fix or remove working piece.
 - B- When the normal maintenance, service, adjustment or repairing.
 - C- When the operator leaves the machine.
 - D- When correct work table adjustment and depth position.
 - E- When change or remove the drilling bit or tooling.
27. Working temp.5 --- 40°C, Humidity 40--- 50, Elevation 0 ---1000 M

Storage temp -25--- 55°C

28. Operate location diagram for reference.

Diagram 1		Diagram 2	
MODEL	Ultimate loading		
PD-28 series	30 kg		
PD-35 series	50 kg		

3-1. Control panel instruction:

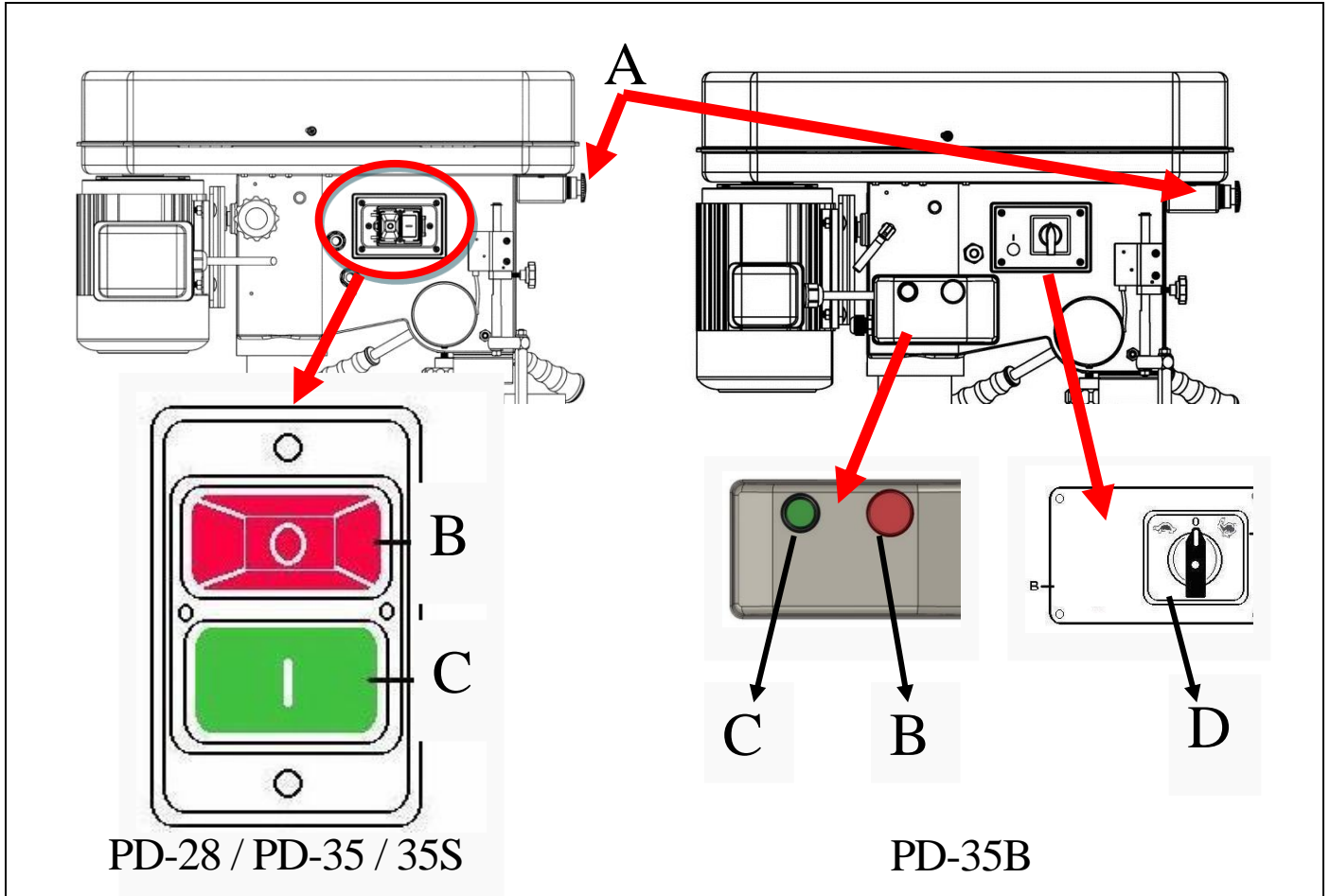

A. Emergency Stop Button

B. Stop Button

C. Start Button

D. Jkm Cam Switch (low /stop/ high)

1. Check the power source
Push the start button to judge the motor and spindle shaft is in normal condition or not.

2. If it needs to stop urgently, just push the emergency stop switch.

3-2. Operation illustration and procedure:

1. There are three T grooves in the worktable. It is used to fix the work piece.

1-1. There are two T grooves in the base, too. It is convenient for fixing the longer, heavier and larger working piece.

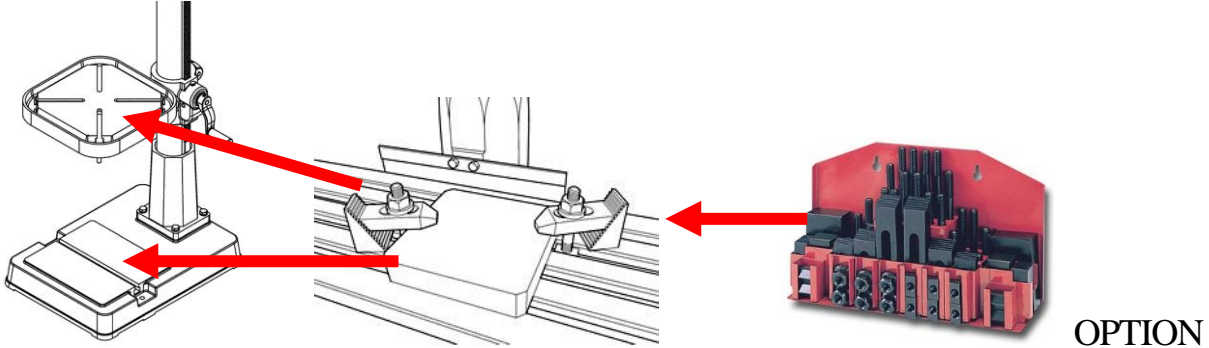

2. The pulley cover is strictly prohibited to open in normal operation condition.



3. Protect safety guard shall be allocated in a proper position in operation. It is controlled by a micro witch.

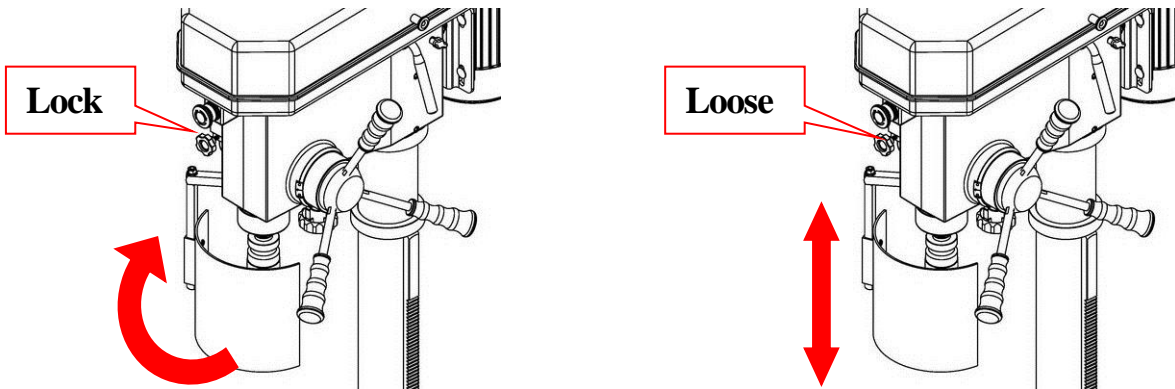

4. Adjustment of feeding limit

To prevent unwanted penetration to work piece, the feeding limit shall be set by adjusting the appropriate position of feeding depth fixing button as long as the distance between the end of tool and top surface if work piece is measured.

A. Setting of feeding depth



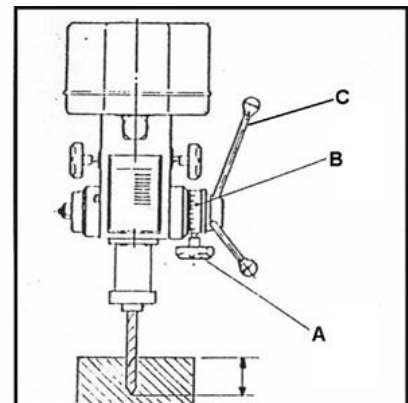







1. Loosen knob A.
2. Turn scaled ring B to desired feeding depth.
3. Lock knob A.



3-3. Operation tips and sound pressure: Speed Selection

Open pulley case and check if spindle speed min-1or/min (R.P.M.) is correct for your job.

Recommended

Drill m/m	Material									
	Cast Iron		Steel		Iron		Aluminium		Alloy Copper	
										
∅2	4780	2390	1275	635	3980	1910	7960	3980	4460	2230
∅3	3185	1590	850	425	2650	1275	5310	2655	2970	1485
∅4	2390	1195	640	320	1990	955	3980	1990	2230	1115
∅5	1910	955	510	255	1590	765	3185	1590	1785	890
∅6	1590	795	425	210	1330	640	2655	1330	1485	745
∅7	1365	680	365	180	1140	545	2275	1140	1275	635
∅8	1195	600	320	160	995	480	1990	995	1115	555
∅9	1060	530	285	140	885	425	1770	885	990	495
∅10	955	480	255	125	800	380	1590	800	890	445
∅11	870	435	230	115	725	350	1450	725	910	405
∅12	795	400	210	105	665	320	1330	665	745	370
∅13	735	365	195	100	610	295	1225	610	685	340
∅14	680	340	180	90	570	270	1135	570	635	320
∅15	640	320	170	85	530	255	1060	530	600	300
∅16	600	300	160	80	500	240	995	500	560	280
∅17	560	280	150	75	470	225	935	470	525	260
∅18	530	265	140	70	440	210	885	440	495	250
∅19	500	250	135	67	420	200	835	420	470	235
∅20	480	240	130	65	400	190	795	400	445	225
∅25	380	190	100	50	320	155	640	320	355	180
∅30	320	160	85	45	265	130	530	265	300	150
∅40	240	120	65	30	200	95	400	200	225	110

note Processing is adjustable on the cutting materials as well as the material of the cutting to real cutting conditions.

A- weighted sound pressure level measuring under no load

Drilling-series Operator position

Lpa= 62 dB(A)

A- weighted sound pressure level measuring under load

Drilling- series Operator position

Lpa= 64 dB(A)

PD-28 / PD-35 series

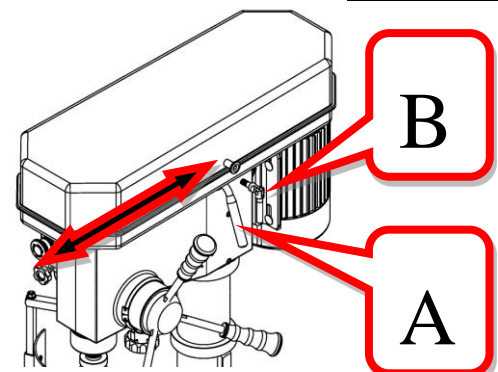
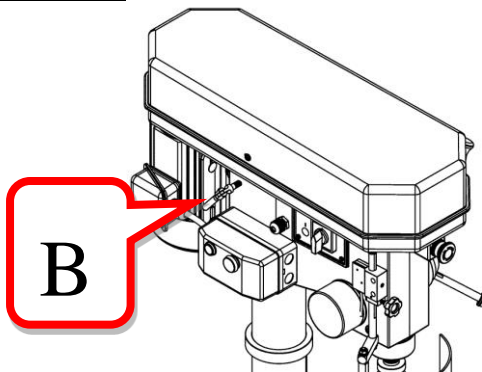

1. Loosen knob B on both sides of headstock.
2. Push handle A forward as arrow sign to get belt tension.
3. Lock knob B firmly to fix belt tension.

When speed change is required. Loosen lead bolt (parts no. 22-S2) on both side of headstock. Pull belt handle (parts no. 26) to allow belts repositioning and then move belts to correct groove to acquire desired speed. See following speed chart for reference.

PD-28

DE = 300	AF = 1130
CE = 390	BG = 1200
DF = 450	CH = 1340
BE = 550	AG = 1730
CF = 620	BH = 1860
DG = 720	AH = 2360

PD-35 / 35S

DE	180
CE	300
DF	320
BE	430
CF	480
DG	620
AF	1050
BG	1200
AG	1680

PD-35B

DE	180	90
CE	300	150
DF	320	160
BE	430	215
CF	480	240
DG	620	310
AF	1050	525
BG	1200	600
AG	1680	840

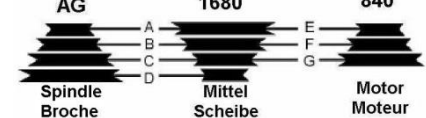
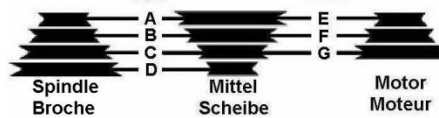

For proper belt tension, use 10 lbs pressure or hand pressure on the belt as shown as bellow.

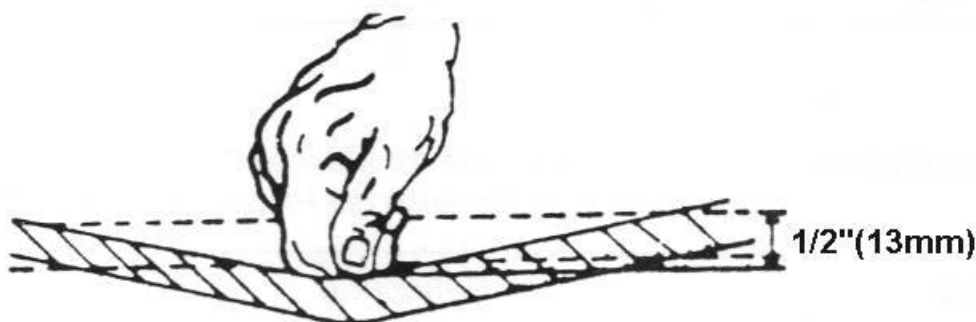

Models belt model tables

Machine model	Belt specifications	Quantity
PD-28 series	Spindle A25 / Motor A26	2
PD-35 series	Spindle LB-35 / Motor B30	2

3-4. Withdraw drill bit :

The arbor can be removed to install another drill chuck in the spindle. A drift key is included to help remove the arbor from the spindle. Usually, once the chuck and arbor have been properly mounted together, they are considered semi-permanent connections.

(If you would like to install a different chuck, we recommend getting a new arbor for that chuck.)

To remove the drill chuck and arbor:

1. Unplug the drill press!
2. Rotate the spindle handles until the drift-key slot is exposed in the side of the quill.
3. Loosen the lock knob and rotate the hub (**Figure 23**) clockwise until it stops.
4. Tighten the lock knob. The quill should not return up into the head casting.
5. Rotate the spindle until the inner drift-key slot is aligned with the outer slot, as shown in (**Figure 24**). You will see through the spindle when the slot is properly aligned.
6. Insert the drift key into the drift-key slot.
7. Tap the drift key with a rubber or wooden mallet, as shown in (**Figure 25**), until the chuck releases.
8. Hold a downfeed handle with one hand, and loosen the lock knob with the other hand.
9. Carefully retract the quill into the headstock.
10. Don't push spindle stroke too long to avoid spindle stick. (**Figure 26**)

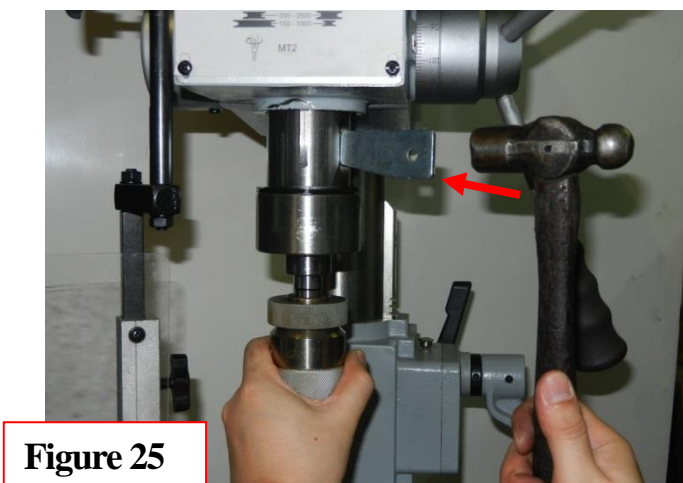
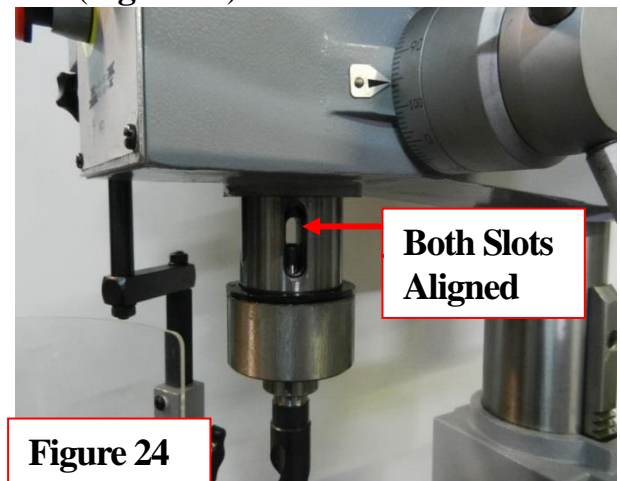
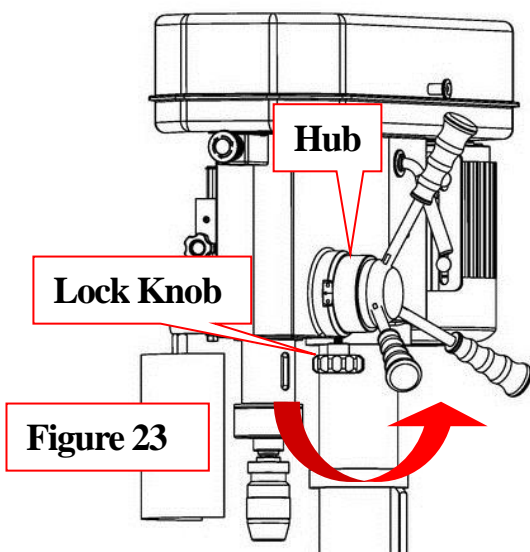

4. Trouble – Shooting;

Warning: Switch off power and remove plug from power source outlet before trouble shooting.

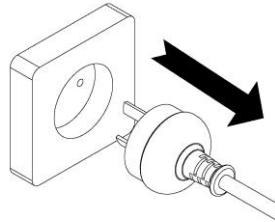

NO.	SYMPTOM	DISPOSITION
1	Drill insert in working piece and spindle shaft stop	<ol style="list-style-type: none"> 1. Push emergency button 2. Turn off the power 3. Use hand to turn the spindle shaft countermarch. Let the tool withdraw from the working piece. 4. Suction the chip on the hole. 5. Turn on power again. 6. Adopt slowly feed make sure in normal condition then recovery the normal feed.
2	Cutting liquid in abnormal condition and can not supply the adequate quantity.	<ol style="list-style-type: none"> 1. Check the pump is running or not 2. Check if the hose is leaking or not.
3	Spindle shaft can not running completely	<ol style="list-style-type: none"> 1. Check the belt tension condition 2. If belt tension is too loose, adjust the belt shifter, otherwise change the aging belt.
4	Motor do not work	<ol style="list-style-type: none"> 1. Check the power and switch 2. Check the power cable is damaged or not if cable is broken, change it directly.
5	Spindle shaft has noise	<ol style="list-style-type: none"> 1. Check bearing 2. Check V – belt, if tightly degree over specific tension will cause noise.
6	Drill oscillation	<ol style="list-style-type: none"> 1. Check chuck condition 2. Make sure the drill is properly fixed in the chuck.

5. Maintenance:

Warning: Switch off power and remove plug from power source outlet before maintenance.

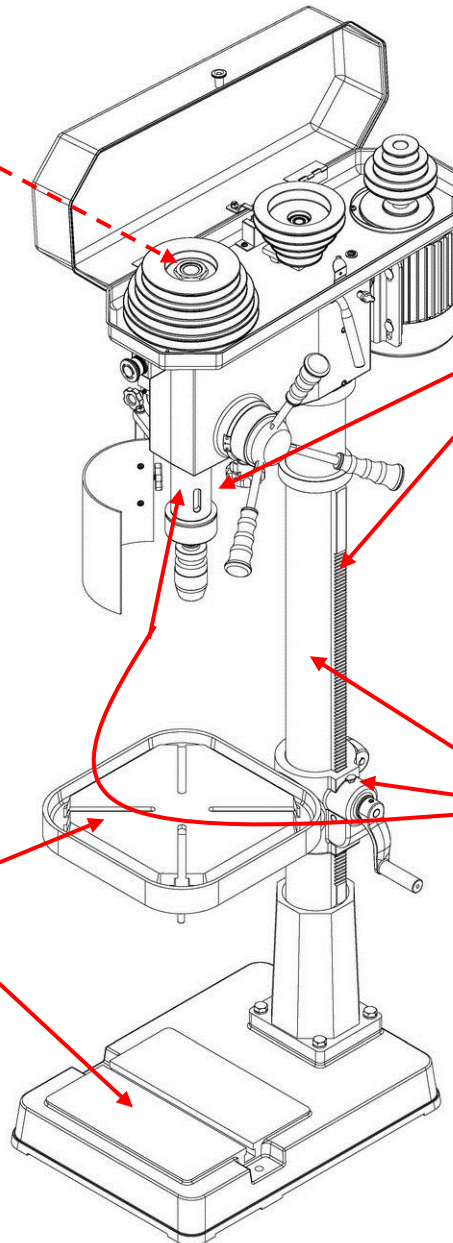
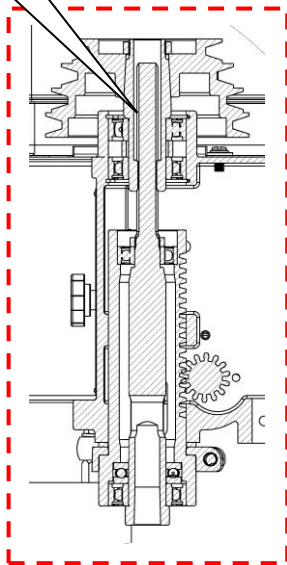
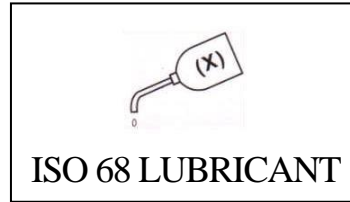
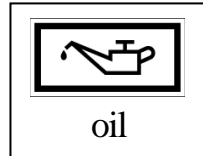
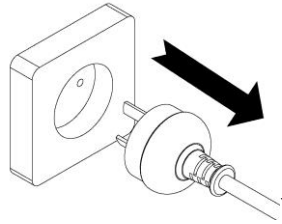

5-1. Feed Shaft Spring Tension:

The feed shaft return spring is adjusted at the factory; however, during the life of the drill press you may want to adjust the feed shaft return spring so the feed shaft return pressure suits your operating needs.

To adjust the feed shaft spring tension:

1. **UNPLUG THE DRILL PRESS !**
2. Wipe off any oil on the spring lock cover so it does not slip in your fingers when you hold the cover from spinning (see **Figure 28**).
3. While holding the spring lock cover against the side of the head stock so the cover stays splined with the locking lug; loosen the jam nut and loosen the cover nut approximately 1/4" (see **Figure 30**).
4. Put on heavy leather gloves to protect your hands from possible lacerations if the spring uncoils during the next step.
5. Pull the cover outward just enough to disengage the spring-cover lock slot from the locking lug. Note: It is important to keep a good grip during this step. Letting go of the cover will cause the spring to rapidly uncoil.
6. Rotate the cover counterclockwise to increase spring tension, or let the cover slowly unwind in the clockwise direction to reduce spring tension.
7. Engage the next available spring-cover lock slot with the locking lug and hold the spring lock cover tightly against the side of the headstock.
8. Snug the cover nut against the spring cover just until the nut stops, and then back off the nut approximately 1/3 turn, or just enough so there is no binding at complete spindle travel.
9. Hold the cover nut and tighten the jam nut against the cover nut.

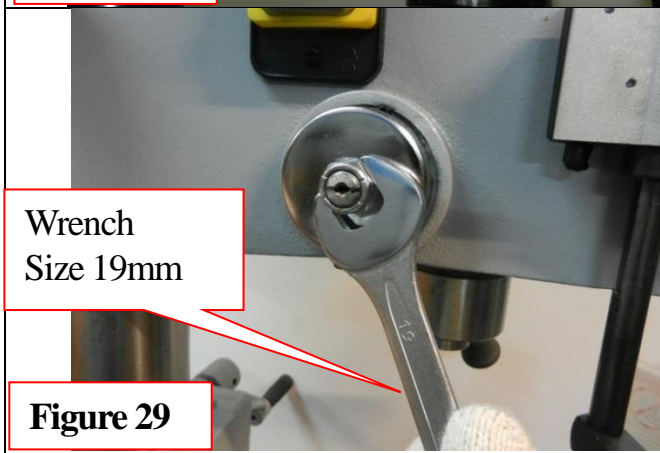
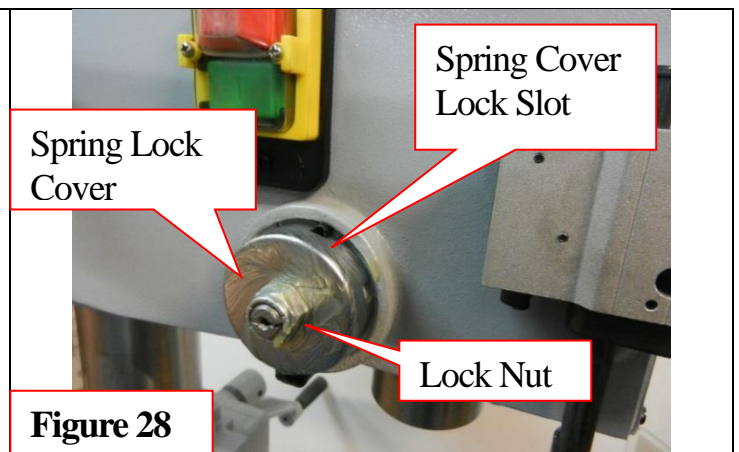

6. Specification;

<i>Model</i>		<i>PD-28</i>	<i>PD-35</i>	<i>PD-35S</i>	<i>PD-35B</i>
Drilling capacity		Ø20mm	Ø25mm		Ø30mm
Tapping capacity		-----	-----		-----
Spindle taper		M.T.#2	M.T.#3		M.T.#3
Spindle travel		80mm	125mm		125mm
Spindle speed (rpm)		300 – 2360/min	180 – 1680/min		90 – 1680/min
Number of speeds		12 steps	9 steps		9×2 steps
Motor		0.75kW / 240V 1Ph			0.75kW / 415V 3Ph
Net weight (kgs)		N.W-98Kg	N.W-143Kg	N.W-135Kg	N.W-154Kg

Dimensions(m/m)

	PD-28	PD-35 / 35B	PD-35S
A	1710	1660	1285
B	472	450	
C	C=500 × c1=330		
D	D×d1=280	D=350 × d1=350	
E	750	720	460
F	1280	1140	765
G	640	725	
H	180	225	
I	Ø80	Ø92	
T	12	12	

7. Control circuit diagram and component part list;

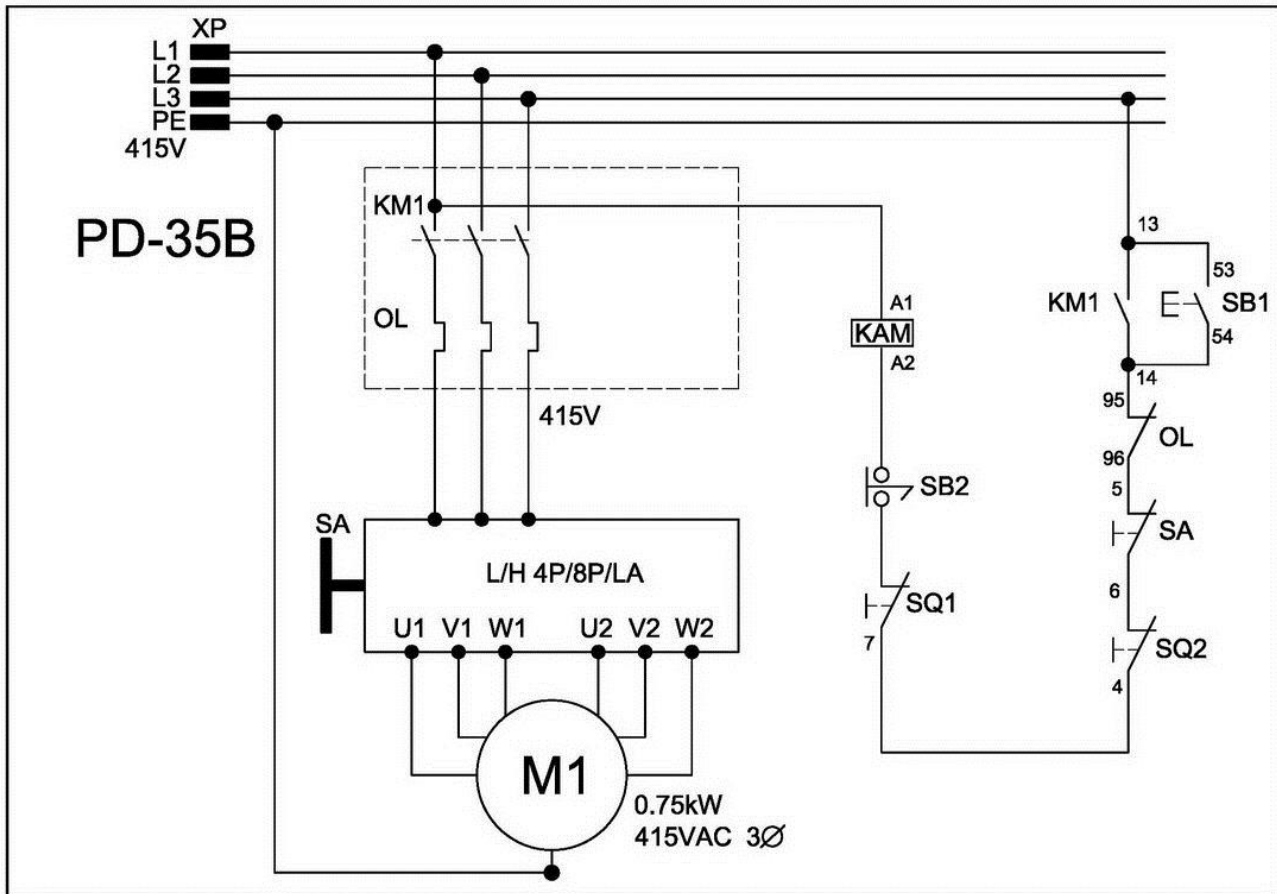

PARTS LIST

PD-35B

Part No.	Component/Object	Type/Model	Ratings/Technical Data	Pcs
M1	MOTOR	PD-35B	0.75kW/415V 50Hz/3PH	1
KM1	MAGNETIC CONTACTOR	HUEB-11K (CU-11)	415V/24A	1
OL	SERIES OVERLOAD RELAY	RHU-10K1	2.3-3.2A	1
SQ1	LIMIT SWITCH	VM5-00N	5A/250S	1
SQ2	MICRO SWITCH CHUCK GUARD	VM5-00N	5A/250S	1
SB1	PUSH BUTTON	CAN-1	INO AC 480V, 1.5A	1
SB2	EMERGENCY STOP	ALEPB25-1/C	INC AC 250V, 3A	1
SA	CAM SWITCH	AC-22A	AC600V 16A	1



PD-28
 PD-35
 PD-35S

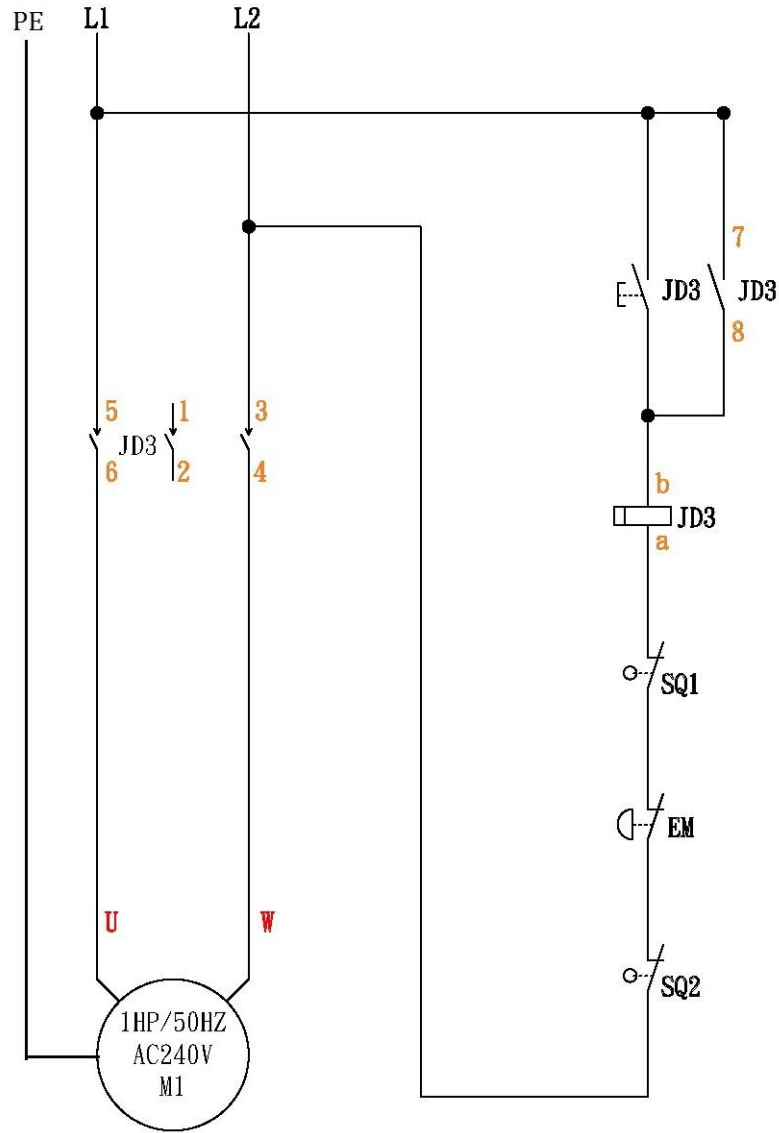

PARTS LIST

PD-28/35/35S

Part No.	Component/Object	Type/Model	Ratings/Technical Data	Pcs
M1	MOTOR	PD-28/35/35S	1HP/240V 50Hz/1PH	1
JD3	CONTACT RELAY	JD3	AC 230V 16A	1
SQ1	LIMIT SWITCH	VM5-00N	5A/250S	1
SQ2	MICRO SWITCH CHUCK GUARD	VM5-00N	5A/250S	1
EM	EMERGENCY STOP	ALEPB25-1/C	INC AC 250V, 3A	1



8. Drawing and parts list;

PD-28/35/35S

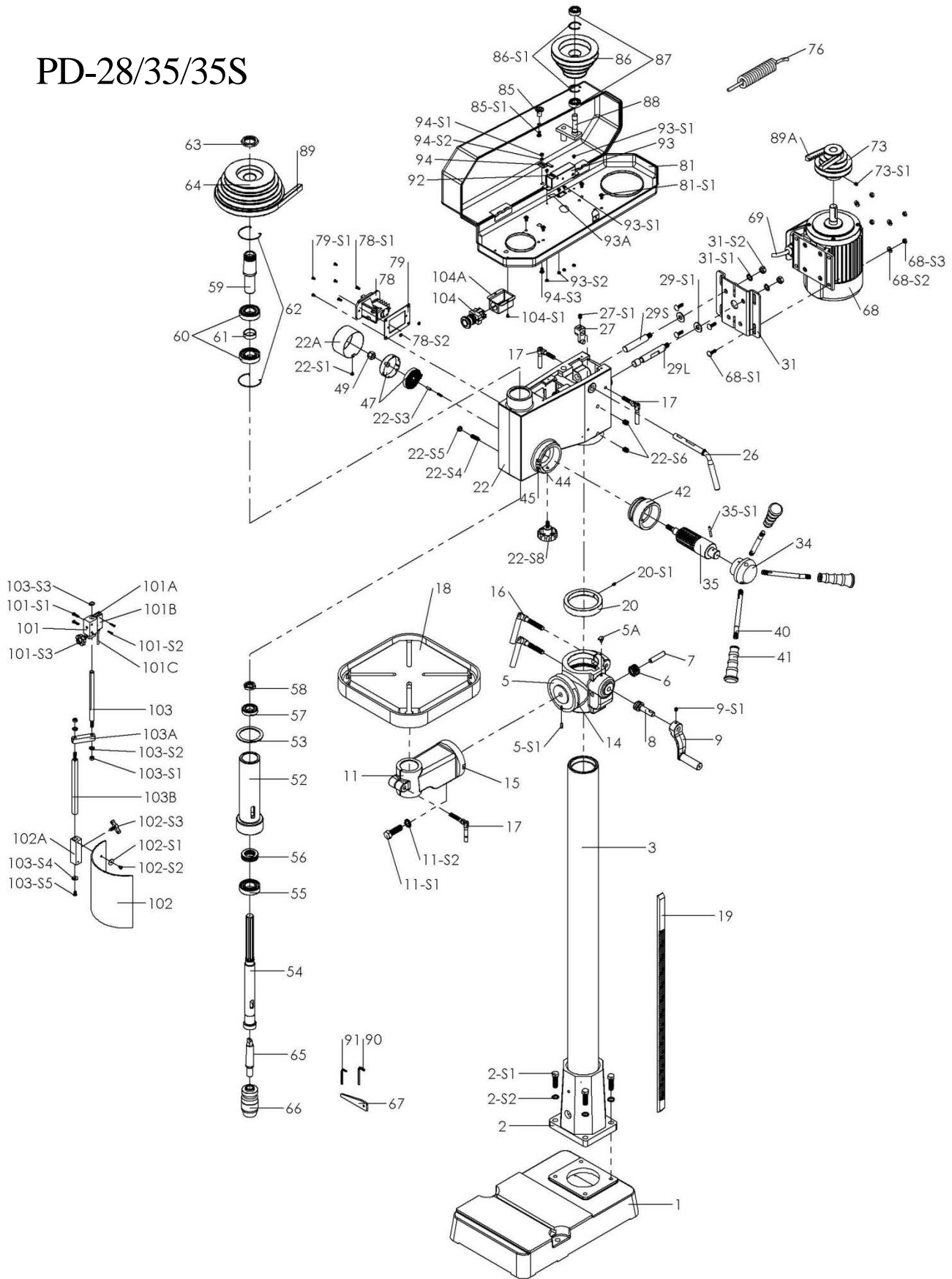

PD-35B

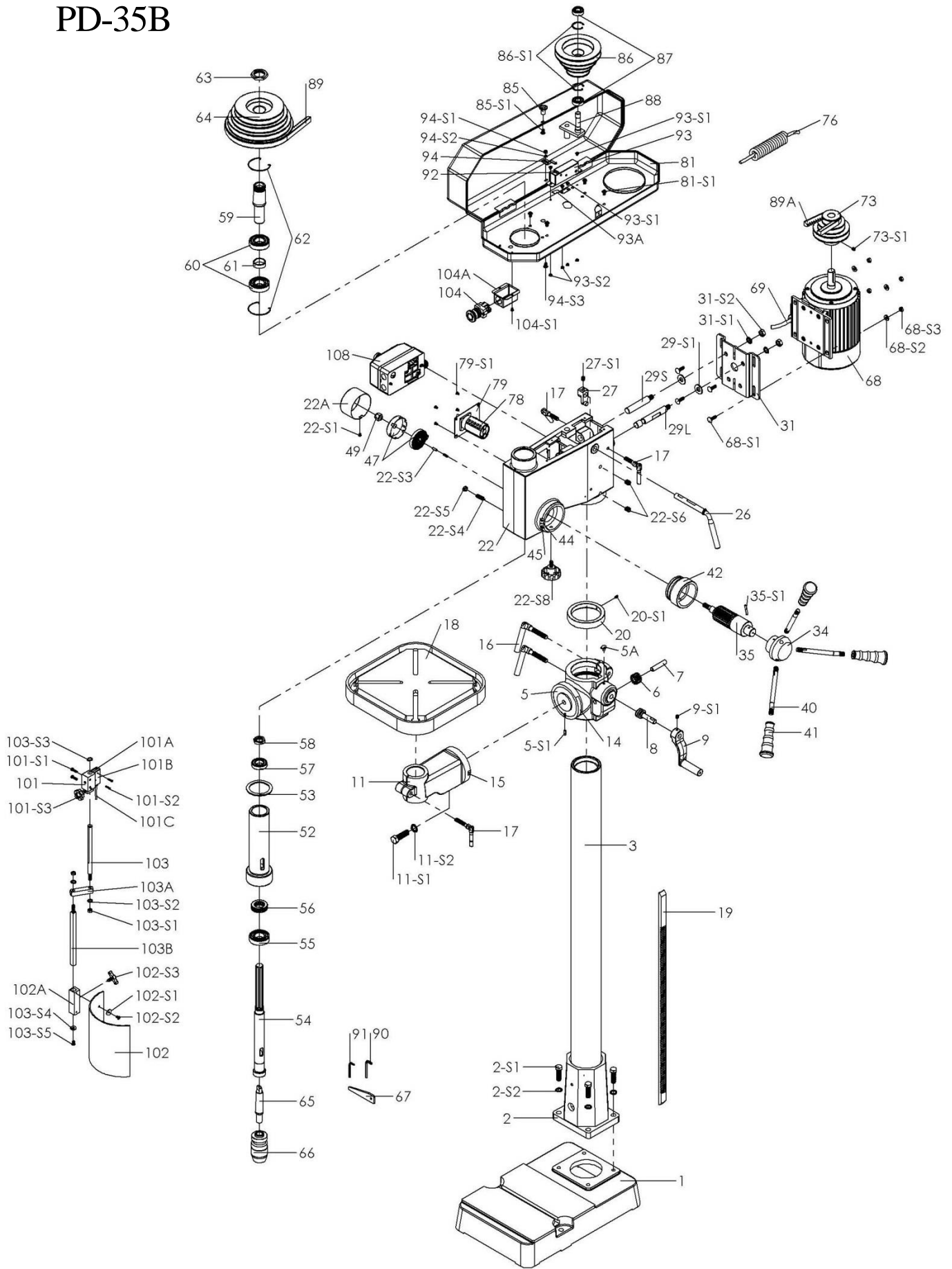

PD-35 series

1	BASE
2	COLUMN HOLDER
2-S1	BOLT
2-S2	SPRING WASHER
3	COLUMN
5	TABLE BRACKET
5A	OIL CUP
5-S1	PIN
6	GEAR
7	GEAR BRACKET
8	WORM
9	TABLE HANDLE
9-S1	SET SCREW
11	TABLE ARM BRACKET
11-S1	BOLT
11-S2	SPRING WASHER
14	ANGLE SCALE
15	SCALE
16	CLAMP HANDLE
17	TABLE BOLT
18	TABLE SWIVEL TYPE
19	RACK
20	RACK RING
20-S1	SET SCREW
22	HEAD BODY
22A	FEED SHIFT COVER
22-S1	SCREW
22-S3	PIN
22-S4	SET SCREW
22-S5	NUT
22-S6	SET SCREW
22-S8	LEAD BOLT
26	SHIFTER BAR
27	SHIFTER
27-S1	SET SCREW
29L	SLIDE BAR (L)
29S	SLIDE BAR (S)
29-S1	WASHER
31	MOTOR BASE
31-S1	SPRING WASHER
31-S2	NUT
34	HANDLE BODY
35	FEED SHAFT
35-S1	PIN
40	FEED HANDLE
41	GRIP
42	SCALE RING
44	ANGLE SCALE
45	RIVET
47	SPRING CAP
49	NUT

52	QUILL
53	RUBBER WASHER
54	SPINDLE
55	BALL BEARING
56	THRUST BEARING
57	BALL BEARING
58	SPINDLE NUT
59	SPINDLE SLEEVE
60	BALL BEARING
61	COLLAR
62	SNAPRING
63	PULLEY NUT
64	SPINDLE PULLEY
65	TAPER ARBOR
66	DRILL CHUCK
67	DRILL SHIFTER
68	MOTOR
68-S1	BOLT
68-S2	WASHER
68-S3	NUT
69	MOTOR WIRE
73	MOTOR PULLEY
73-S1	SET SCREW
76	WIRE
78	SWITCH
78	CAN SWITCH (ForPD-35B)
78-S1	SCREW
78-S2	NUT
79	SWITCH COVER
79-S1	SCREW
81	PULLEY COVER
81-S1	SCREW
85	PULLEY COVER KNOB
85-S1	PULLEY COVER SCREW
86	TRANSMITTING PULLEY
86-S1	SNAPRING
87	BALL BEARING
88	PULLEY SHAFT
89	V-BELT
90	ALLEN WRENCHL
91	ALLEN WRENCHS
92	MICRO SWITCH
93	MICRO SWITCH BOX
93A	SPRING SHEET
93-S1	SCREW
93-S2	NUT
94	CLUTCH
94-S1	NUT
94-S2	SPRING WASHER
94-S3	SCREW
101	MICRO SWITCH BRACKET
101A	MICRO SWITCH
101B	MICRO SWITCH BOARD COVER
101C	MICRO SWITCH WIRE

101-S1	SCREW
101-S2	SCREW
101-S3	LEAD BOLT
102	SAFETY GUARD
102A	SAFETY GUARD SLIDE
102-S1	WASHER
102-S2	SCREW
102-S3	LEAD BOLT
103	BRACKET ROD
103A	SUPPORT ARM
103B	LOWER BRACKET ROD
103-S1	HEX NUT
103-S2	SPRING WASHER
103-S3	C-RING
103-S4	WASHER
103-S5	SCREW
104	EMERGENCY STOP SWTCH
104A	SWITCH COVER
104-S1	SCREW
108	MAGNETIC SWITCH